

ErP
Ready

Shinhoo[®]
CANNED MOTOR PUMP



HIGH EFFICIENCY

High Efficiency Circulation Pump

Shinhoo
CANNED MOTOR PUMP

HEFEI XINHU CANNED MOTOR PUMP CO., LTD
No.1 Yanglin Road, Hi-Tech District, Hefei, Anhui, 230088, China
Tel: +86 551 62379803/07 Fax: +86 551 62379801 Web: www.shinhoodump.com

HIGH EFFICIENCY

High Efficiency Circulation Pump

230V 50/60Hz

As a member unit of national pump standardization technical committee as well as Crane, Metallurgical Motors and Canned Motors standardization technical committee of national electric rotating machinery standardization technical committee, we participated drafting work of a series of standards regarding canned motor and canned motor pumps. We are committed to product research and development as well as quality promotion with orientation of customers' requirement. We offer professional solutions for general and special requirements regarding non-leakages delivery of various kinds for fluid. Our products are sold abroad to many countries in America, Europe, Asia and other areas, being widely used in chemical industry, petrifaction, petroleum refining, textile industry, locomotive, central air conditioning, aerospace, military industry, nuclear power, air conditioning system cooling and heating circulation, construction, environment protection, ventilation and new energy. With reliable quality and attentive service, we have gained a high reputation in the market.

We sincerely hope to cooperate with you for a splendid future together.

TABLE OF CONTENTS

05

Brief Introduction

06

Product Introduction

34

GPA IV

42

GPA XX-11

08

GPA II

16

GPA II BL

48

GPA 15-1.5

52

GPA 15-1.5BL

22

GPA III

28

LPA

56

GPA15-6F

BRIEF INTRODUCTION

Introduction of Hefei Xinhua Canned Motor Pump Co., Ltd. (Shinhoo) As a wholly-owned subsidiary of Zhejiang Dayuan Pumps Industrial Co., Ltd. (Shanghai Stock Exchange-stock code: 603757), Shinhoo is specialized in canned motor pump manufacturing. In order to satisfy the rising market demands, in 2007 our large production base was constructed with the total investment of 300 million Chinese Yuan in National Hi-Tech Developing Zone in Hefei, Anhui Province, China. In the end of 2009, our new plant with the floor area of 100,000 square meters started running. Based on the standard of ISO 9001:2015 Quality Management System, ISO14001:2015 Environment Management System and OHSAS18001:2007 Occupation Health and Safety Management System, Shinhoo established a complete set of design, producing, marketing and service system. As required by different countries and areas, our related products successfully obtained certifications such as CCC, GS, UL and CE as well as passed required tests such as RoHS, REACH and EEI. All of these ensured the safety, stability, reliability, durability and legality of our products in the market. We have formed our own core competitiveness as well as the space for sustainable development with sufficient material resources, reinforced regulation system and hightech talents we gathered.



PRODUCT INTRODUCTION

FEATURES:

Shinhoo high efficiency circulation pump is high efficiency pump for water circulation, which features well-designed compact structure, integrated controller and frequency converter. It is easy for installation and operation in most fields of applications. In terms of electricity consumption, the unique operation mode makes Shinhoo high efficiency circulation pump more energy saving.

FIELDS OF APPLICATIONS:

1. System with constant or variable flow
2. System with variable temperature liquid
3. System with night mode
4. Air conditioning and cooling system
5. Industrial circulation system
6. Domestic hot water and drinking water supply system

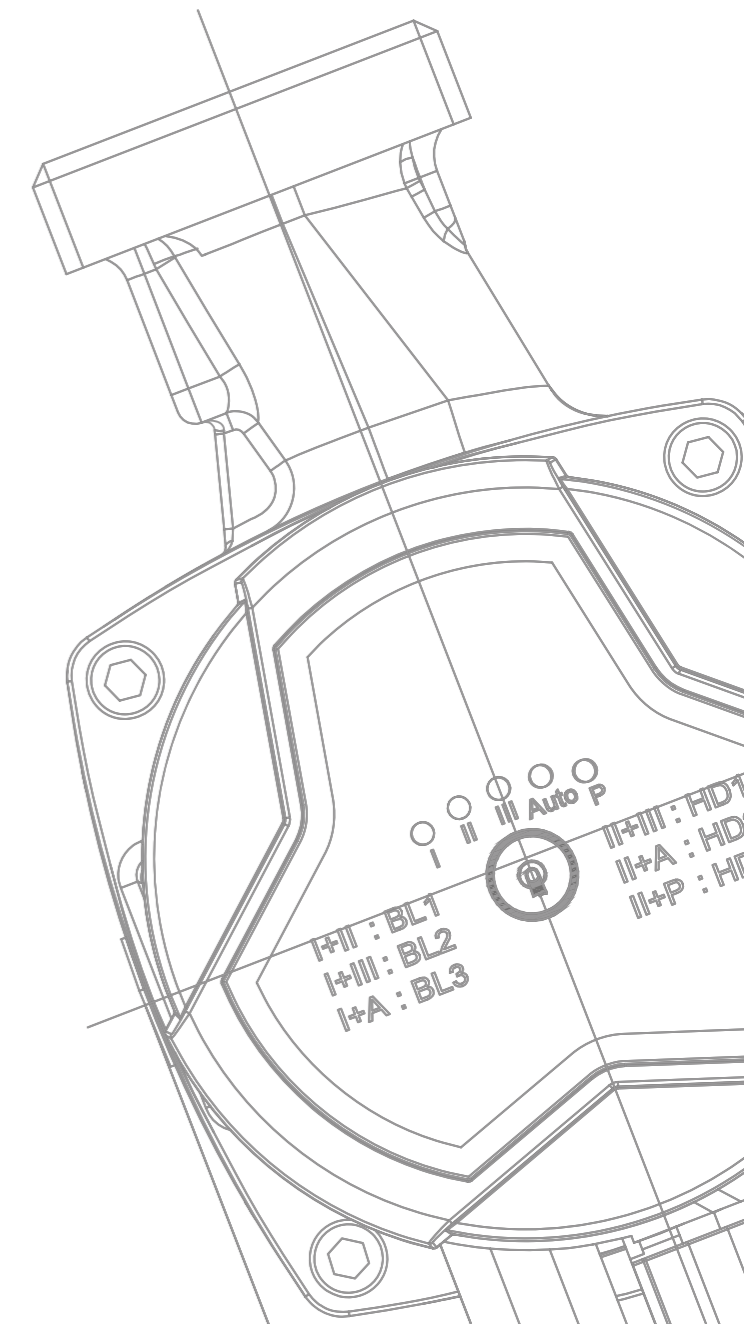
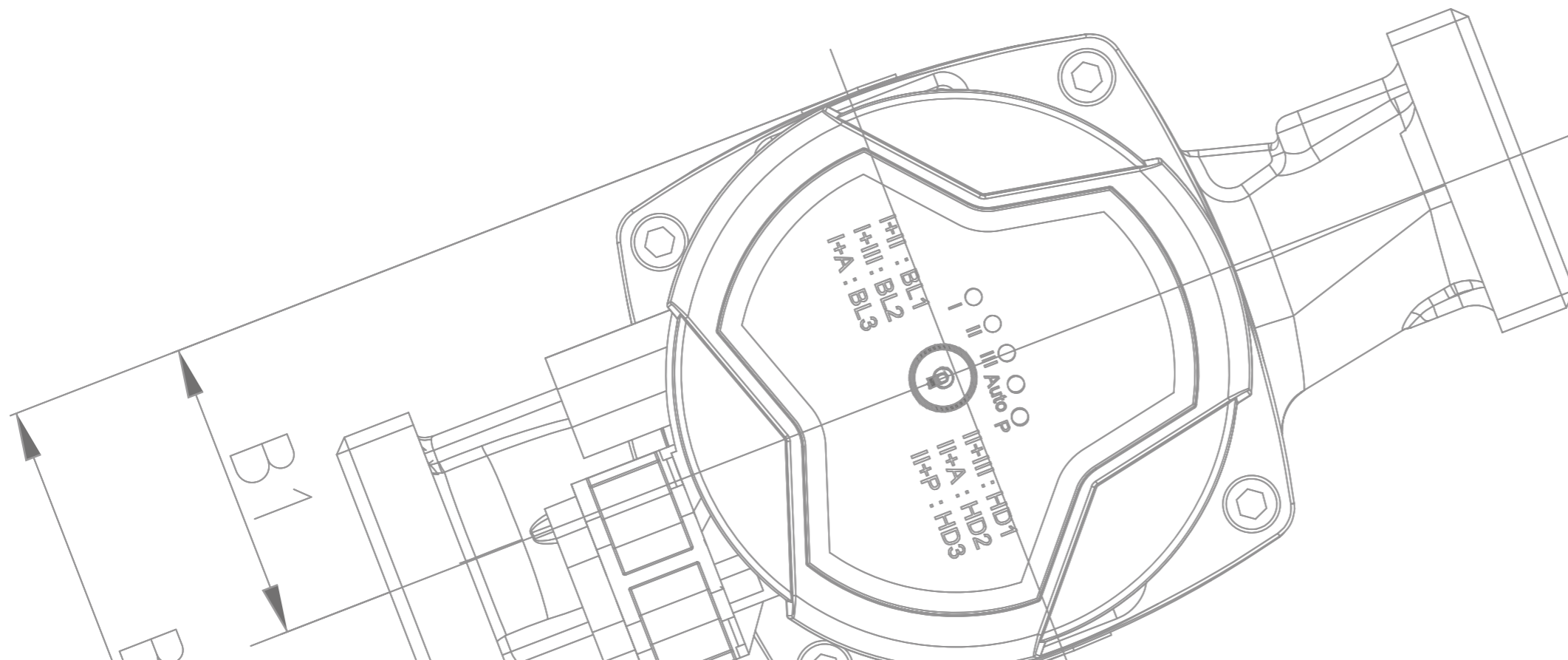

GPA II

High Efficiency Circulation Pump



Knob model

Button model

Applications

1. Domestic heating and hot water supply systems
2. Air and ground source heat pump systems
3. Air-conditioning systems
4. Industrial hot water circulation systems
5. Solar thermal systems

Features and benefits

Easy installation and operation

Equipped with Self Adapting mode AUTO (default setting), pump runs once the power is connected and adapts its performance according to actual system needs.

Control is effected by digital pulse-width modulation (PWM) low-voltage signal, enabling the pump to be used to meet different flow requirement in various systems.

Low noise and high comfort

Noise index: $\leq 42\text{dB(A)}$

Low energy consumption

A class energy efficiency, lowest power consumption up to 5W.

Multiple protection

With over-voltage and over-current protection

Eco-Design Benchmark

$\text{EEI} \leq 0.20\text{-Part 2}$

Two versions, to meet different requirements of usages.

1. Button model, to switch modes with button
2. Rotary control model, easy operation

Quick release power plug

Start-up and stop the pump quickly.

Product photo and control modes



Setting	Explanation
AUTO (factory setting)	Proportional pressure curve descending from highest to lowest
BL1	Min. proportional pressure curve
BL2	Max. proportional pressure curve
HD1	Min. constant pressure curve
HD2	Max. constant pressure curve
III	Rate III
II	Rate II
I	Rate I
PWM	PWM duty cycle performance curve

Night mode

- Press button to switch between control modes,
- Press night mode button to switch to night mode.

Running lights

- Switch between AUTO and Min-Max with rotary control

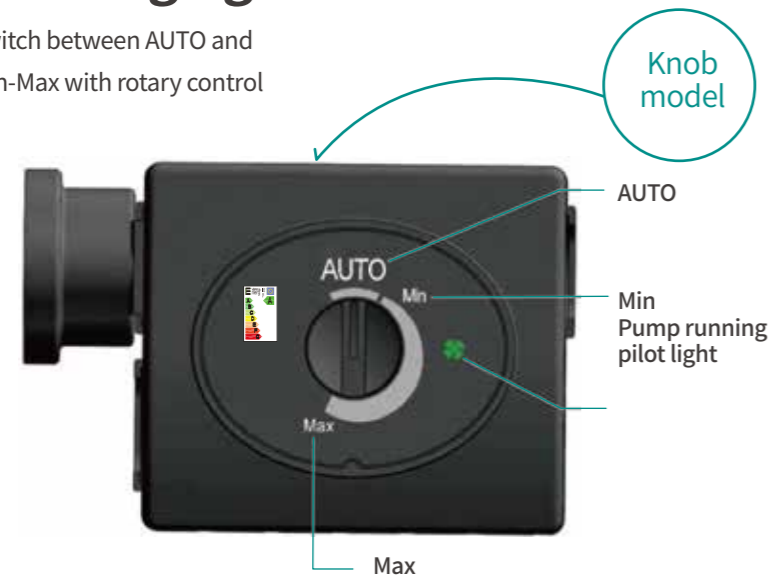

Setting	Explanation
AUTO (factory setting)	Proportional pressure curve descending from highest to lowest
Continuously viable	"Min-Max" curve

Technical parameter

Technical data

Power supply voltage	220-240V 50/60Hz, protective earth
Motor protection	No external protection required
IP class	IP42
Insulation class	H
(RH) Humidity	Max. 95%
System pressure	1.0 MPa
Compliance	CE/ GS/ EMC/ LVD/RoHS/REACH
Environment temperature	0~+40°C
Temperature class	TF110
Liquid temperature	-30~+110°C (Glycol up to 50%)

Button model performance curves

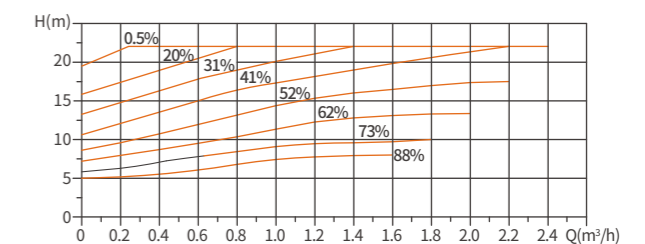
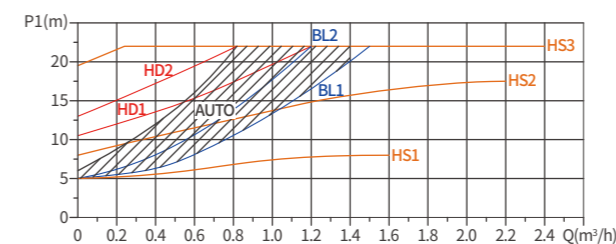
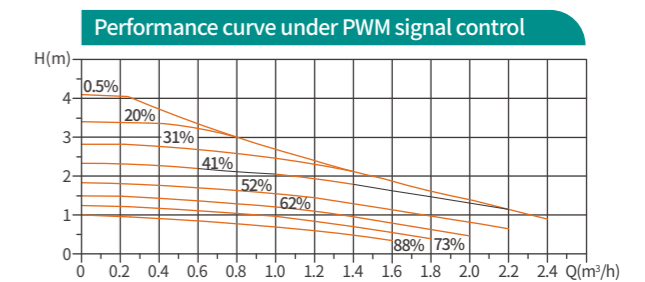
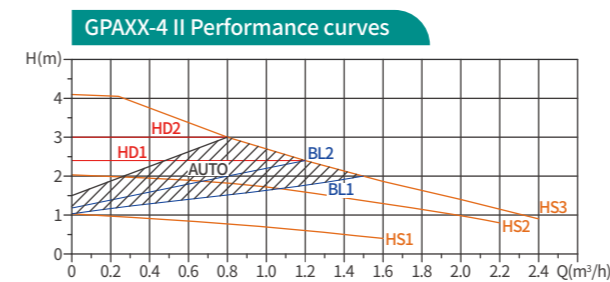

Rotary control model performance curves

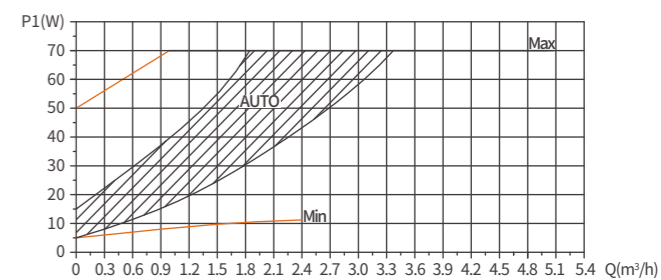
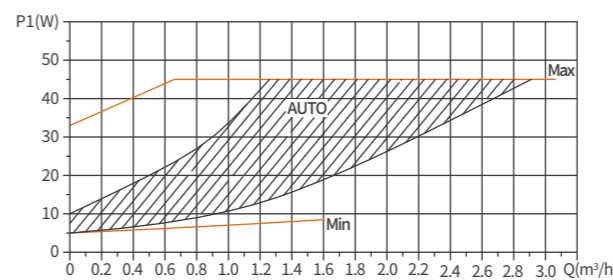
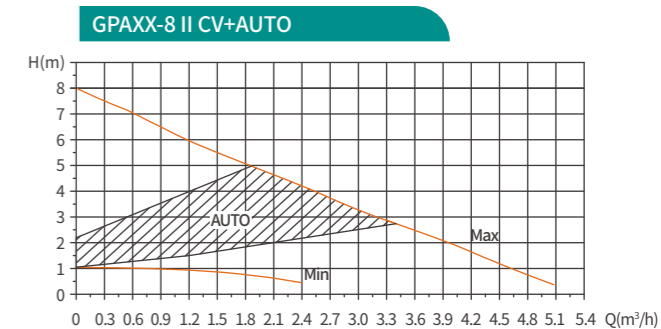
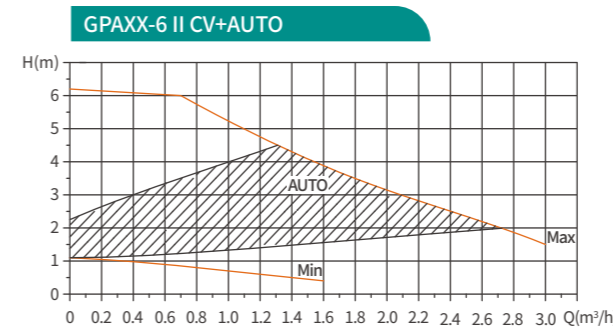
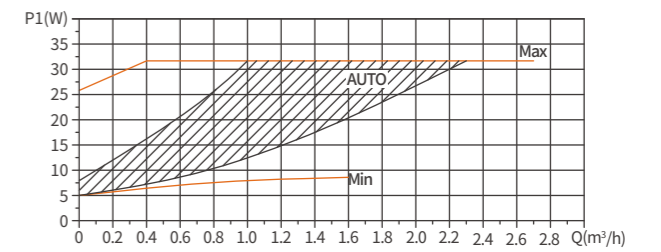
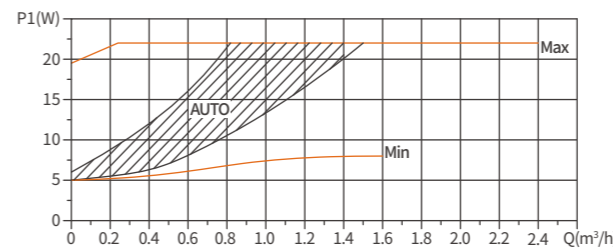
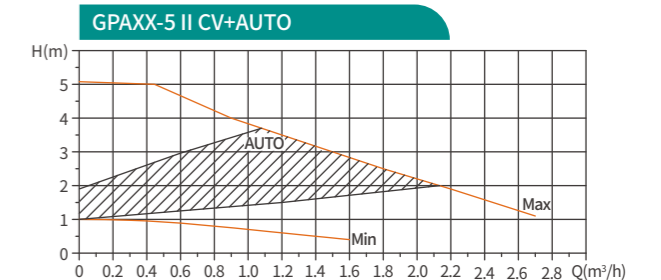
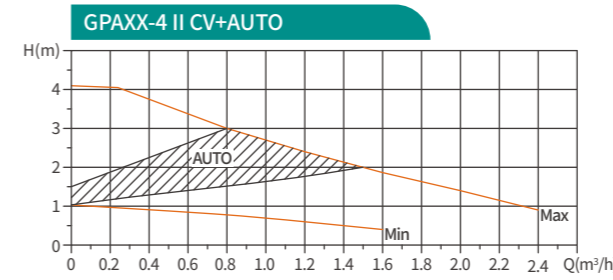
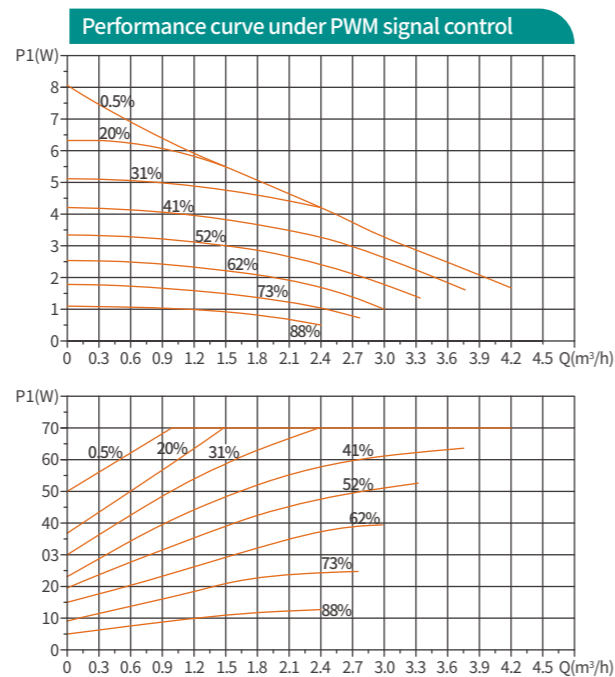
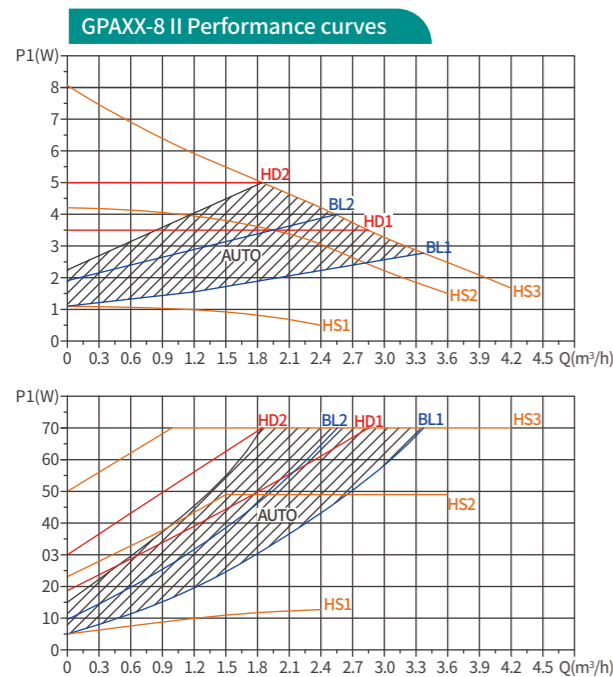
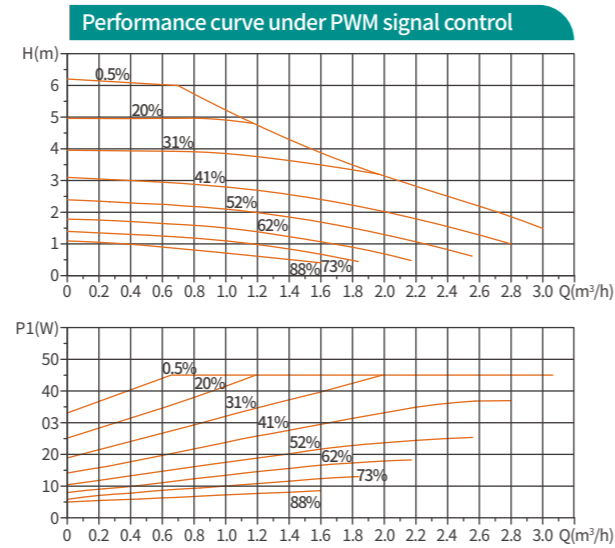
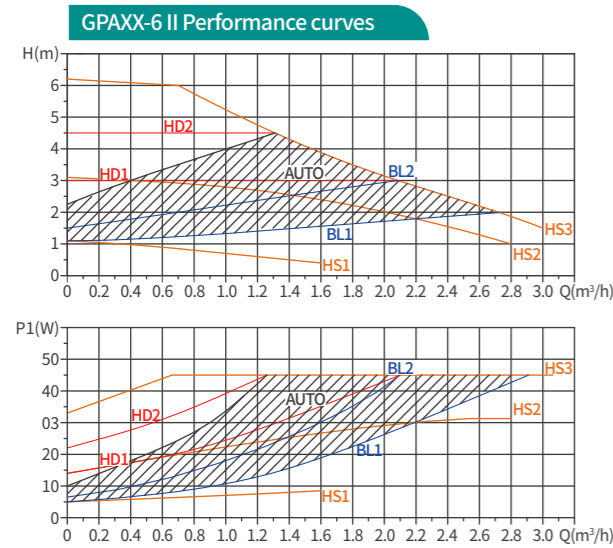
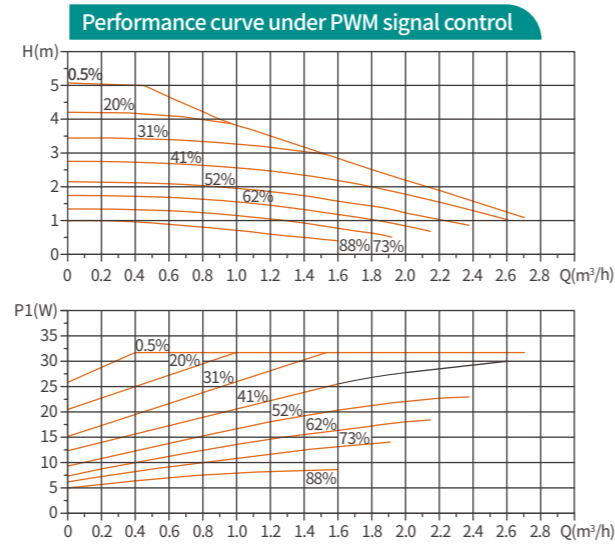
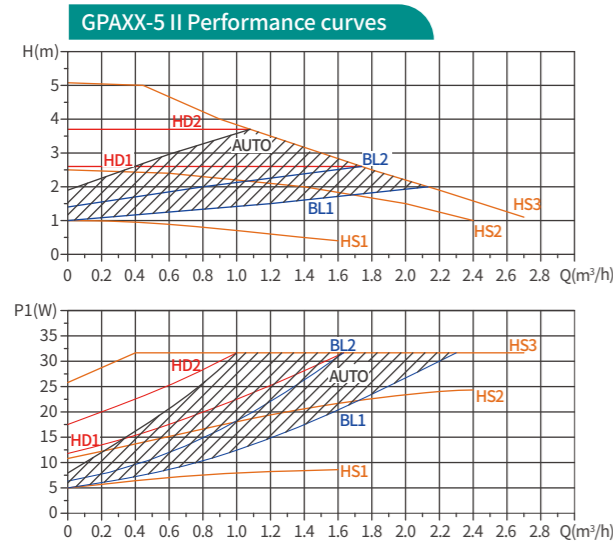

Installation drawing and performance parameter

Button model

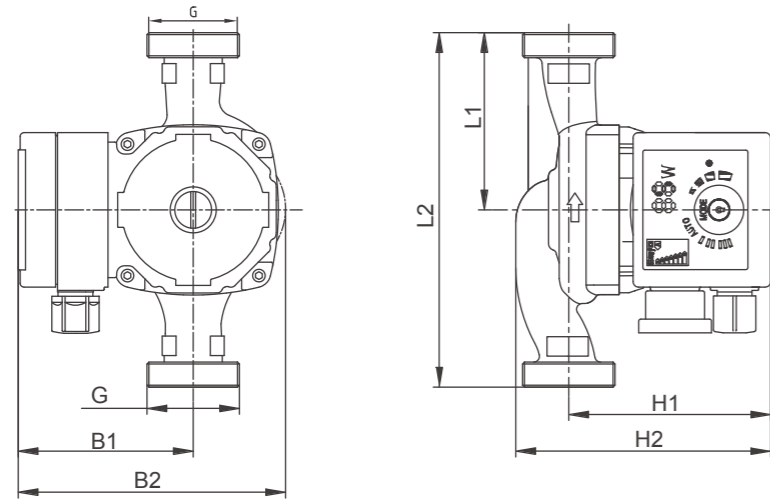

Rotary control model

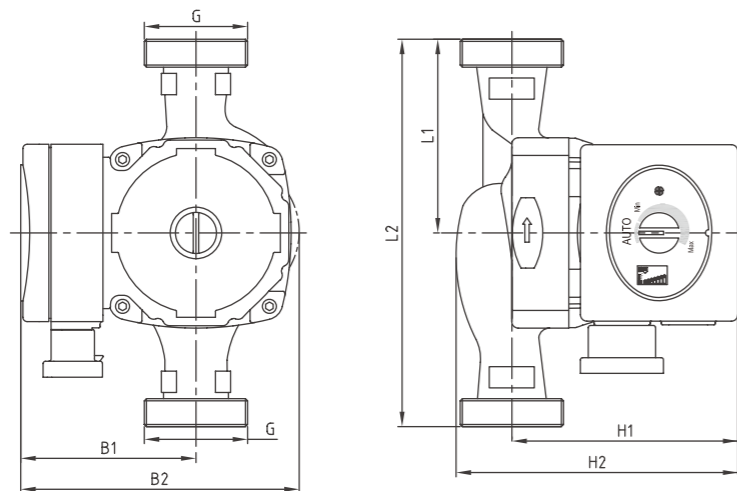

Performance parameter

Power (W)	Model	Max flow (m³/h)	Max Head (m)	Current (A)	Voltage/Frequency (230V 50Hz/60Hz)	Pump body material				Dimensions							Package size (mm³mm³mm)		Wt.(kg)	
						Cast iron	Plastic	Brass	Stainless steel	L1	L2	B1	B2	H1	H2	G	Inner box	G.W.	N.W.	
22	GPA20-4 II	2.3	4	0.19	●	●	●	●	●	65	130	82	130	103	127	1"	155x140x165	2.4	1.9	
	GPA25-4 II	2.5			●	●	●	●	●	65	130	82	130	103	130	11/2"	155x140x165	2.9	2.1	
		75			150	82	130	103	130	200x165x155	3.1	2.3								
		90			180	82	130	103	130	200x165x155	3.2	2.4								
GPA32-4 II	3.0	●	●	●	●	90	180	82	130	102	132	2"	200x165x155	3.5	2.5					
32	GPA20-5 II	2.5	5	0.27	●	●	●	●	●	65	130	82	130	103	127	1"	155x140x165	2.4	1.9	
	GPA25-5 II	3.0			●	●	●	●	65	130	82	130	103	130	11/2"	155x140x165	2.9	2.1		
		75			150	82	130	103	130	200x165x155	3.1	2.3								
		90			180	82	130	103	130	200x165x155	3.2	2.4								
GPA32-5 II	3.5	●	●	●	●	90	180	82	130	102	132	2"	200x165x155	3.5	2.5					
45	GPA20-6 II	2.8	6	0.38	●	●	●	●	●	65	130	82	130	103	127	1"	155x140x165	2.4	1.9	
	GPA25-6 II	3.2			●	●	●	●	65	130	82	130	103	130	11/2"	155x140x165	2.9	2.1		
		75			150	82	130	103	130	200x165x155	3.1	2.3								
		90			180	82	130	103	130	200x165x155	3.2	2.4								
GPA32-6 II	4.0	●	●	●	●	90	180	83	130	102	132	2"	200x165x155	3.5	2.5					
70	GPA20-8 II	3.4	8	0.52	●	●	●	●	●	65	130	88	136	103	127	1"	155x140x165	2.9	2.1	
	GPA25-8 II	4.0			●	●	●	●	65	130	88	136	103	130	11/2"	155x140x165	2.9	2.1		
		75			150	88	136	103	130	200x165x155	3.1	2.3								
		90			180	88	136	103	130	200x165x155	3.2	2.4								
GPA32-8 II	5.0	●	●	●	●	90	180	88	136	102	132	2"	200x165x155	3.5	2.5					

GPA II BL

High Efficiency Circulation Pump



Applications

1. Domestic heating and hot water supply systems
2. Air and ground source heat pump systems
3. Air-conditioning systems
4. Industrial hot water circulation systems
5. Solar thermal system

Features and benefits

Easy installation and operation

Equipped with Self Adapting mode AUTO (default setting), pump runs once the power is connected and adapts its performance according to actual system needs.

Low noise and high comfort

Noise index: $\leq 42\text{dB(A)}$

Low energy consumption

A class energy efficiency, lowest power consumption up to 5W.

Multiple protection

With over-voltage and over-current protection

Eco-Design Benchmark

$\text{EEI} \leq 0.20\text{-Part 2}$

Quick release power plug

Start-up and stop the pump quickly.

Product photo and control modes

Running lights

Switch between AUTO and Min-Max with button

Product photo and control modes



Technical parameter

Technical data

Power supply voltage	220-240V 50/60Hz, protective earth
Motor protection	The pump needs no external protection
IP class	IP44
Insulation class	H
(RH) Humidity	Max. 95%
System pressure	1.0 MPa
Compliance	CE/ GS/ EMC/ LVD/RoHS/REACH
Environment temperature	0~+40°C
Temperature class	TF110
Liquid temperature	-30~+110°C(Glycol up to 50%)

Performance curves

Performance GPA××-4 II BL Series

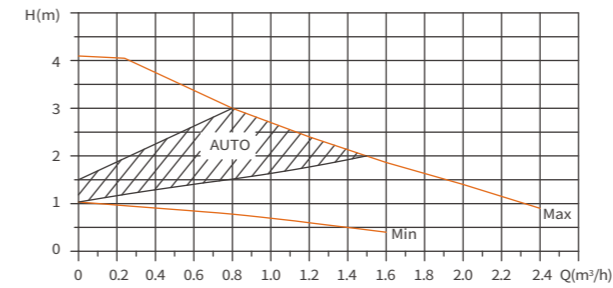

Performance GPA××-5 II BL Series

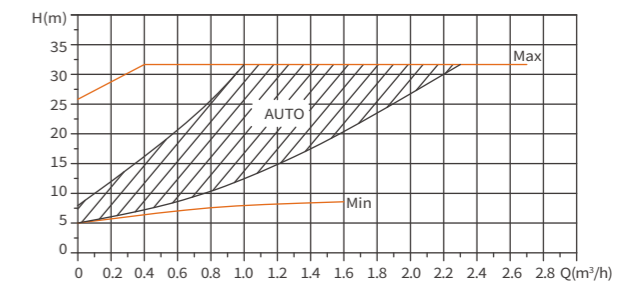
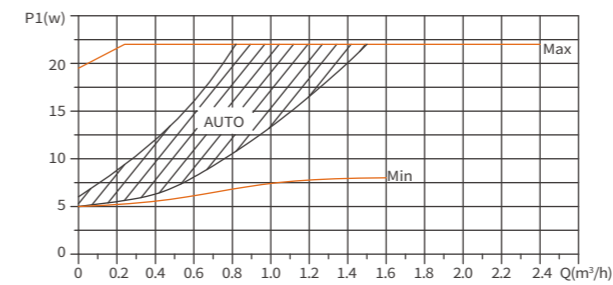
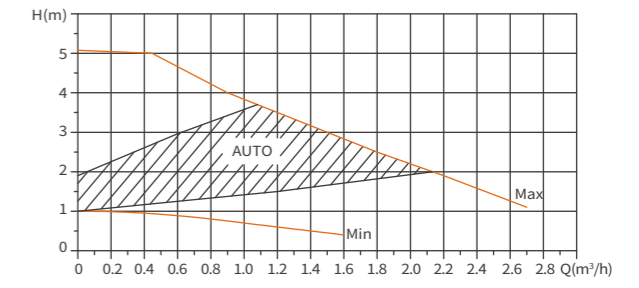

Performance GPA××-6 II BL Series

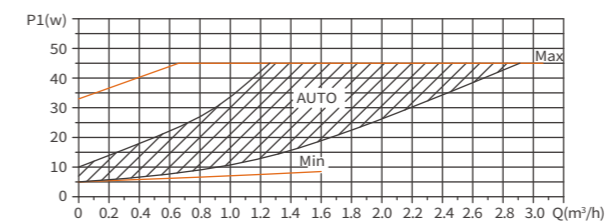
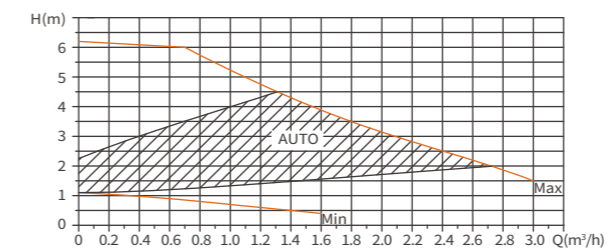

Installation drawing and performance parameter

Installation drawing

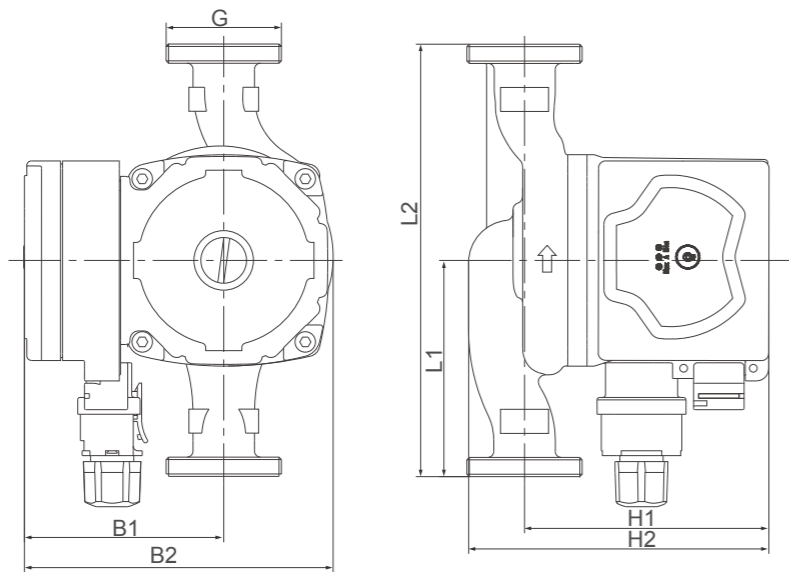

Performance parameter

Power (W)	Model	Max Flow (m³/h)	Max Head (m)	Current (A)	Voltage/ Frequency		Pump body material				Dimensions							Package size (mm*mm*mm)		Wt.(kg)	
					230V	50/60Hz	Cast iron	Plastic	Brass	Stainless steel	L1	L2	B1	B2	H1	H2	G	Inner box	G.W.	N.W.	
22	GPA20-4II BL	2.3	4	0.19	●	●	●	●	●	65	130	82	130	103	127	1"	155x140x165	2.4	1.9		
	GPA25-4II BL	2.5			●	●	●	●	65	130	82	130	103	130	11/2"	155x140x165	2.9	2.1			
		3.0			●	●	●	●	75	150	82	130	103	130		200x165x155	3.1	2.3			
32	GPA20-5II BL	2.5	5	0.27	●	●	●	●	●	65	130	82	130	103	127	1"	155x140x165	2.4	1.9		
		3.0			●	●	●	●	65	130	82	130	103	130	11/2"	155x140x165	2.9	2.1			
	3.5	●			●	●	●	75	150	82	130	103	130	200x165x155		3.1	2.3				
45	GPA20-6II BL	2.8	6	0.38	●	●	●	●	●	65	130	82	130	103	127	1"	155x140x165	2.4	1.9		
		3.2			●	●	●	●	65	130	82	130	103	130	11/2"	155x140x165	2.9	2.1			
	4.0	●			●	●	●	75	150	82	130	103	130	200x165x155		3.1	2.3				
	GPA32-6II BL	3.2			●	●	●	●	●	90	180	82	130	103	130	200x165x155	3.2	2.4			
	GPA32-6II BL	4.0			●	●	●	●	●	90	180	82	130	102	132	2"	200x165x155	3.5	2.5		

GPA III

High Efficiency Circulation Pump



Applications

1. Domestic heating and hot water supply systems
2. Air and ground source heat pump systems
3. Air-conditioning systems
4. Industrial hot water circulation systems
5. Solar thermal system

Features and benefits

Easy installation and operation

Equipped with Self Adapting mode AUTO (default setting), pump runs once the power is connected and adapts its performance according to actual system needs.

Control is effected by digital pulse-width modulation (PWM) low-voltage signal, enabling the pump to be used to meet different flow requirement in various systems.

Low noise and high comfort

Noise index: $\leq 42\text{dB(A)}$

Low energy consumption

A class energy efficiency, lowest power consumption up to 5W.

Multiple protection

With over-voltage and over-current protection

Eco-Design Benchmark

EEI ≤ 0.20 -Part 2

Quick release power plug

Start-up and stop the pump quickly.

Product photo and control modes



◀ Press button to switch between different control modes.
(HS1, HS2, HS3, AUTO, BL1, BL2, BL3, HD1, HD2, HD3)

Lighting area	Explanation	As shown in the figure
Factory settings	Highest to Lowest Proportional Pressure Curve	
HS1	Velocity I	
HS2	Velocity II	
HS3	Velocity III	
BL1	Lowest Proportional Pressure Curve	
BL2	Intermediate Proportional Pressure Curve	
BL3	Highest Proportional Pressure Curve	
HD1	Lowest Constant Pressure Curve	
HD2	Intermediate Constant Pressure Curve	
HD3	Highest Constant Pressure Curve	
PWM	Duty cycle and rotational velocity curve	

Technical parameter

Technical data

Power supply voltage	220-240V 50/60Hz, protective earth
Motor protection	No external protection required
IP class	IP44
Insulation class	H
Humidity (RH)	Max 95%
System pressure	1.0 MPa
Compliance	CE/ GS/ EMC/ LVD/RoHS/REACH
Environment temperature	0~+70°C
Temperature class	TF110
Liquid temperature	-30~+110°C(Glycol up to 50%)

Performance curves

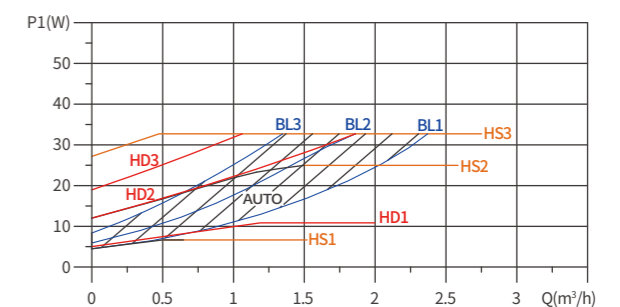
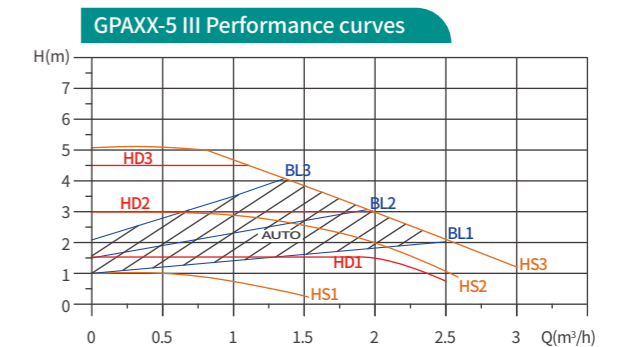
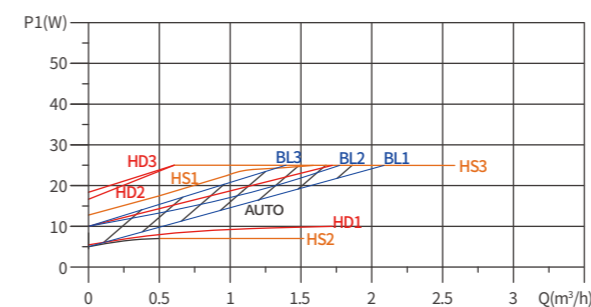
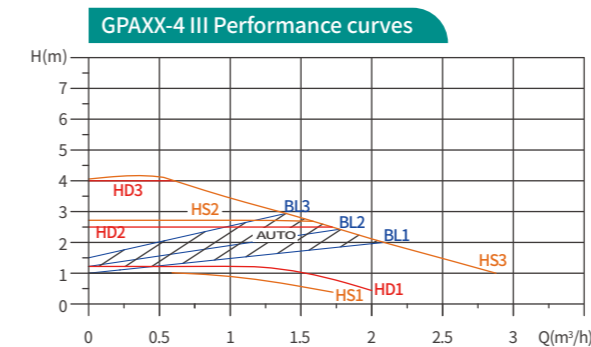

Installation drawing and performance parameter

Installation drawing

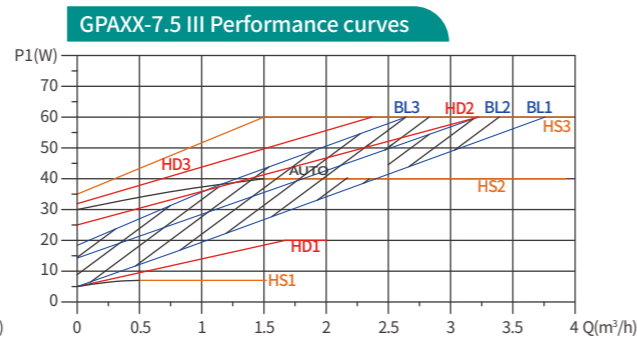
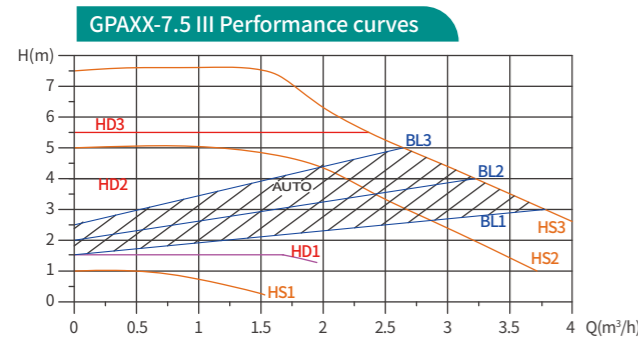
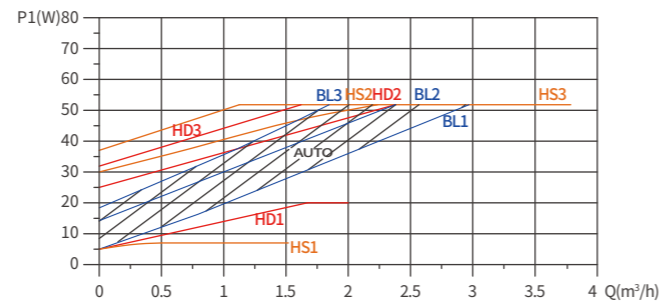
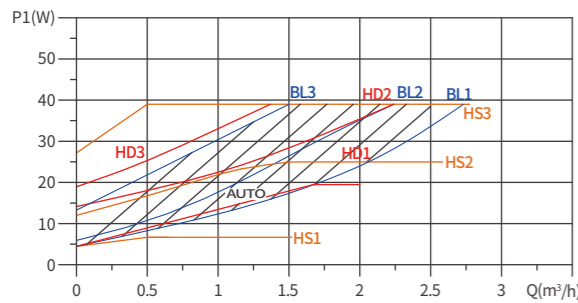
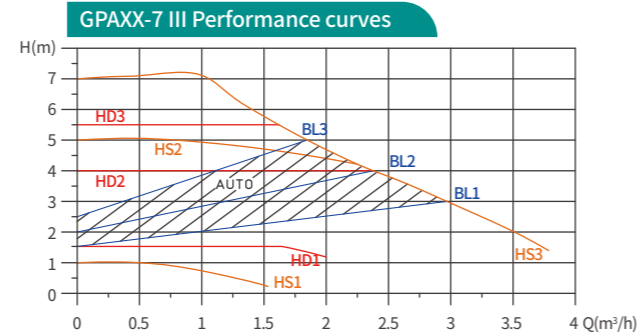
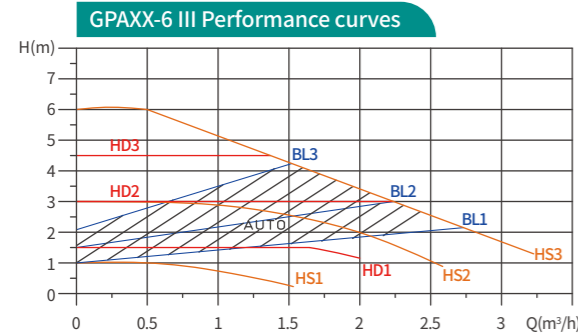
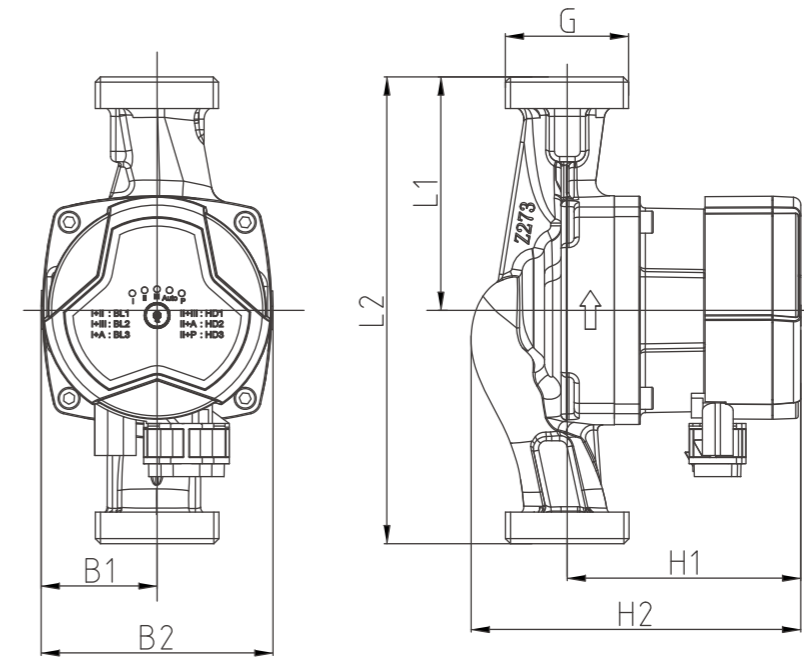

Performance parameter

Power (W)	Model	Max. Flow (m³/h)	Max. Head (m)	Amps (A)	V/Hz	Material of pump housing				Dimension (mm)						Package size (mm*mm*mm)		Wt. (kg)	
						Cast Iron	Plastic	Copper	Stainless Steel	L1	L2	B1	B2	H1	H2	G	Inner box	G.W.	N.W.
25	GPA20-4 III	2.2	4	0.25	230V 50/60Hz	●	●	●	●	65	130	45	90	94	122	1"	155x140x165	2.1	1.6
	GPA25-4 III	2.5				●	●	●	●	65	130	45	90	90	127	1 1/2"	155x140x165	2.3	1.8
	GPA32-4 III	2.8				●	●	●	●	90	180	45	90	90	127	2"	200x165x155	2.5	1.9
33	GPA20-5 III	2.3	5	0.30	230V 50/60Hz	●	●	●	●	65	130	45	90	94	122	1"	155x140x165	2.1	1.6
	GPA25-5 III	2.8				●	●	●	●	65	130	45	90	90	127	1 1/2"	155x140x165	2.3	1.8
	GPA32-5 III	3.2				●	●	●	●	90	180	45	90	90	127	2"	200x165x155	2.9	2.0
39	GPA20-6 III	2.8	6	0.35	230V 50/60Hz	●	●	●	●	65	130	45	90	94	122	1"	155x140x165	2.1	1.6
	GPA25-6 III	3.2				●	●	●	●	65	130	45	90	90	127	1 1/2"	155x140x165	2.3	1.8
	GPA32-6 III	3.6				●	●	●	●	90	180	45	90	90	127	2"	200x165x155	2.9	2.0
52	GPA20-7 III	2.8	7	0.45	230V 50/60Hz	●	●	●	●	65	130	45	90	94	122	1"	155x140x165	2.1	1.6
	GPA25-7 III	3.4				●	●	●	●	65	130	45	90	90	127	1 1/2"	155x140x165	2.3	1.8
	GPA32-7 III	3.8				●	●	●	●	90	180	45	90	90	127	2"	200x165x155	2.5	1.9
60	GPA20-7.5 III	2.8	7.5	0.50	230V 50/60Hz	●	●	●	●	65	130	45	90	94	122	1"	155x140x165	2.1	1.6
	GPA25-7.5 III	3.4				●	●	●	●	65	130	45	90	90	127	1 1/2"	155x140x165	2.3	1.8
	GPA32-7.5 III	3.8				●	●	●	●	90	180	45	90	90	127	2"	200x165x155	2.5	1.9

LPA

High Efficiency Circulation Pump



Applications

1. Domestic heating and hot water supply systems
2. Air and ground source heat pump systems
3. Air-conditioning systems
4. Industrial hot water circulation systems
5. Solar thermal system

Features and benefits

Easy installation and operation

Equipped with Self Adapting mode AUTO (default setting), pump runs once the power is connected and adapts its performance according to actual system needs.

Low noise and high comfort

Noise index: $\leq 42\text{dB(A)}$

Low energy consumption

A class energy efficiency, lowest power consumption up to 5W.

Multiple protection

With over-voltage and over-current protection

Eco-Design Benchmark

$\text{EEI} \leq 0.20\text{-Part 2}$

Quick release power plug

Start-up and stop the pump quickly.

Product photo and control modes



Setting	Explanation
AUTO (factory setting)	Proportional pressure curve descending from highest to lowest
BL1	Min. proportional pressure curve
BL2	Max. proportional pressure curve
HD1	Min. constant pressure curve
HD2	Max. constant pressure curve
III	Rate III
II	Rate II
I	Rate I
Night mode	Night mode

◀ (HS1, HS2, HS3, AUTO, BL1, BL2, HD1, HD2)
 Press button to switch between different control modes,
 Press night mode button to switch to night mode.

Technical parameter

Technical data

Power supply voltage	220-240V 50/60Hz, protective earth
Motor protection	No external protection required
IP class	IP42
Insulation class	H
(RH) Humidity	Max. 95%
System pressure	1.0 MPa
Compliance	CE/ GS/ EMC/ LVD/RoHS/REACH
Environment temperature	0~+40°C
Temperature class	TF110
Liquid temperature	-30~+110°C(Glycol up to 50%)

Performance curves

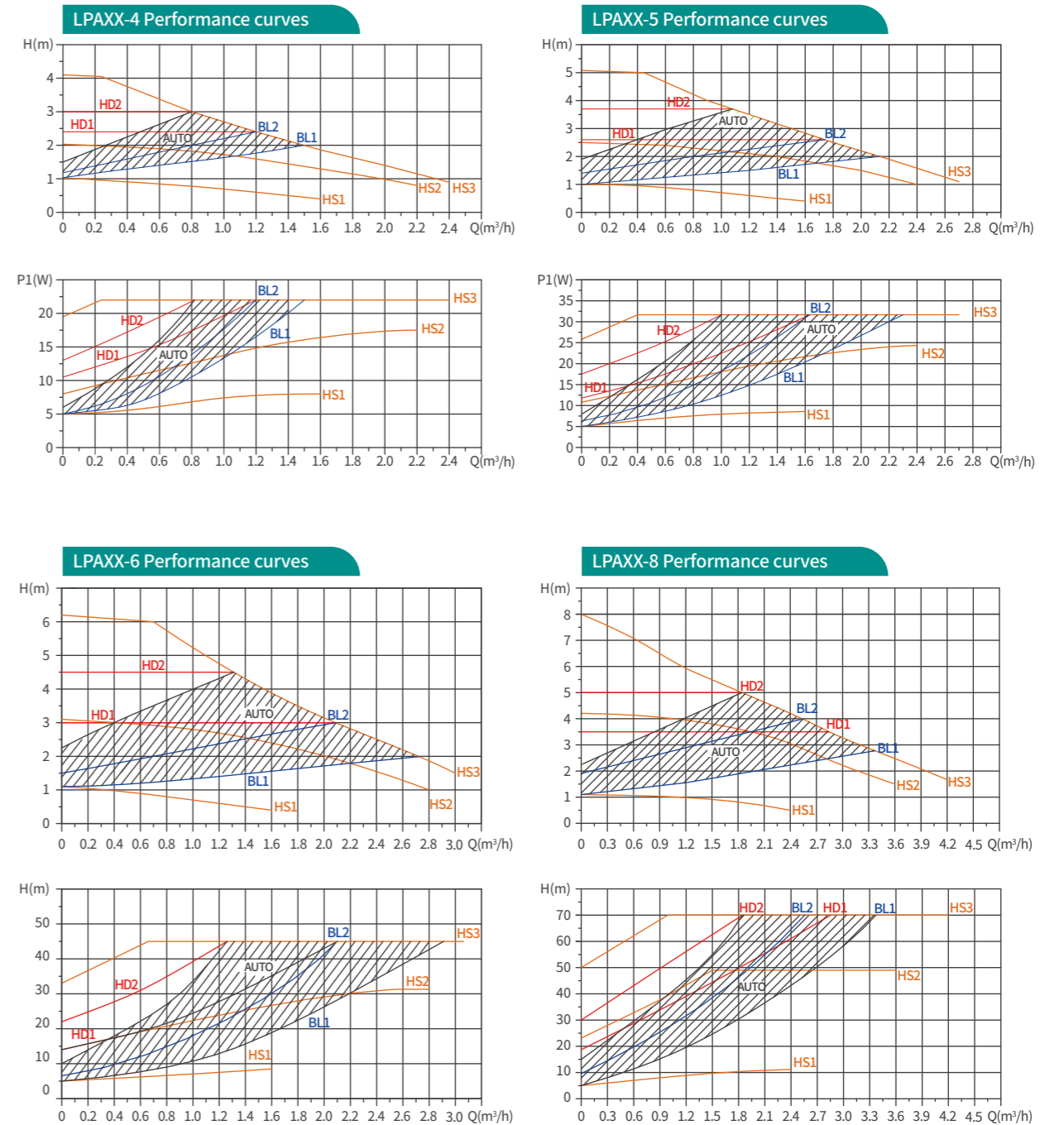

Installation drawing and performance parameter

Installation drawing

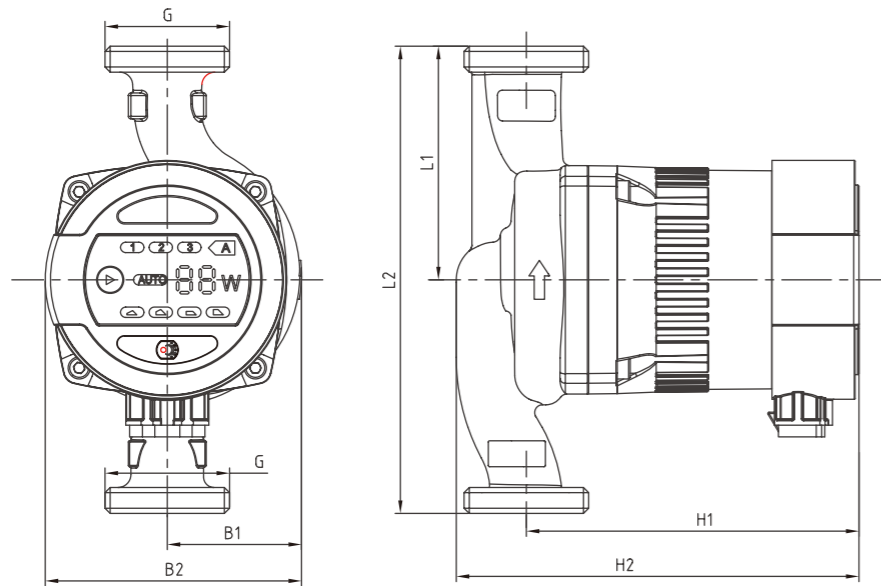

Performance parameter

Power (W)	Model	Max Flow (m³/h)	Max Head (m)	Current (A)	Voltage/ Frequency		Pump body material				Dimensions						Package size (mm*mm*mm)		Wt.(kg)	
					220-240V	50/60Hz	Cast iron	Plastic	Brass	Stainless steel	L1	L2	B1	B2	H2	H3	G	Inner box	G.W.	N.W.
22	LPA20-4	2.3	4	0.19	●	●	●	●	65	130	51	98	133	153	1"	190x170x150	2.4	1.9		
	LPA25-4	2.5			●	●	65	130	52	99	128	156	11/2"	190x170x150	2.9	2.1				
		2.5			●	●	75	150	49	96	131	155		190x170x200	3.1	2.3				
		2.5			●	●	90	180	52	99	128	156		190x170x200	3.2	2.4				
LPA32-4	3.0	●	●	90	180	52	99	128	156	2"	190x170x200	3.5	2.5							
32	LPA20-5	2.5	5	0.27	●	●	●	●	65	130	52	99	133	153	1"	190x170x150	2.4	1.9		
	LPA25-5	3.0			●	●	65	130	52	99	128	156	11/2"	190x170x150	2.9	2.1				
		3.0			●	●	75	150	49	96	131	155		190x170x200	3.1	2.3				
		3.0			●	●	90	180	52	99	128	156		190x170x200	3.2	2.4				
LPA32-5	3.5	●	●	90	180	52	99	128	156	2"	190x170x200	3.5	2.5							
45	LPA20-6	2.8	6	0.38	●	●	●	●	65	130	52	99	133	153	1"	190x170x150	2.4	1.9		
	LPA25-6	3.2			●	●	65	130	52	99	128	156	11/2"	190x170x150	2.9	2.1				
		3.2			●	●	75	150	49	96	131	155		190x170x200	3.1	2.3				
		3.2			●	●	90	180	52	99	128	156		190x170x200	3.2	2.4				
LPA32-6	4.0	●	●	90	180	52	99	128	156	2"	190x170x200	3.5	2.5							
70	LPA20-8	3.4	8	0.52	●	●	●	●	65	130	52	98	133	153	1"	190x170x150	2.4	1.9		
	LPA25-8	4.0			●	●	65	130	52	99	128	156	11/2"	190x170x150	2.9	2.1				
		4.0			●	●	75	150	49	96	131	155		190x170x200	3.1	2.3				
		4.0			●	●	90	180	52	99	128	156		190x170x200	3.2	2.4				
LPA32-8	5.0	●	●	90	180	52	99	128	156	2"	190x170x200	3.5	2.5							

GPA IV

High Efficiency Circulation Pump



Applications

1. Domestic heating and hot water supply systems
2. Air and ground source heat pump systems
3. Air-conditioning systems
4. Industrial hot water circulation systems
5. Solar thermal system

Features and benefits

Easy installation and operation

Equipped with Self Adapting mode AUTO (default setting), pump runs once the power is connected and adapts its performance according to actual system needs.

Control is effected by digital pulse-width modulation (PWM) low-voltage signal, enabling pump to be used to meet different flow requirement in various systems.

Low noise and high comfort

Noise index: $\leq 42\text{dB(A)}$

Low energy consumption

A class energy efficiency, lowest power consumption up to 6W.

Multiple protection

With over-voltage and over-current protection.

Eco-Design Benchmark

EEI ≤ 0.23 -Part 2

Quick release power plug

Start-up and stop the pump quickly.

Product photo and control modes



Setting	Explanation
AUTO (factory setting)	Running within Defined Range
BL	Proportional Pressure Curve
HD	Constant Pressure Curve
HS	Constant Speed Curve

◀ Press button to switch between different control modes and increase or decrease the setting with the buttons on left and right side.

Technical parameter

Technical data

Power supply voltage	220-240V 50/60Hz, protective earth
Motor protection	No external protection required
IP class	IP42
Insulation class	H
(RH) Humidity	Max. 95%
System pressure	1.0 MPa
Compliance	CE/ GS/ EMC/ LVD/RoHS/REACH
Environment temperature	0~+40°C
Temperature class	TF110
Liquid temperature	-30~+110°C(Glycol up to 50%)

Performance curves

GPAXX-6 IV Performance curves (HS+AUTO)

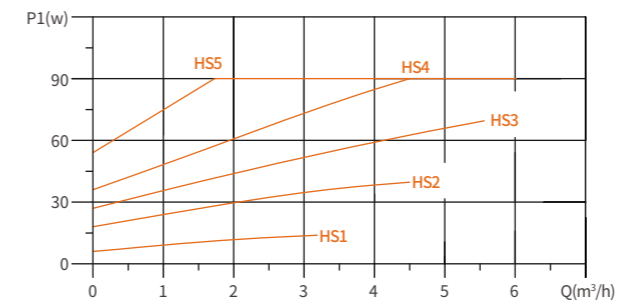
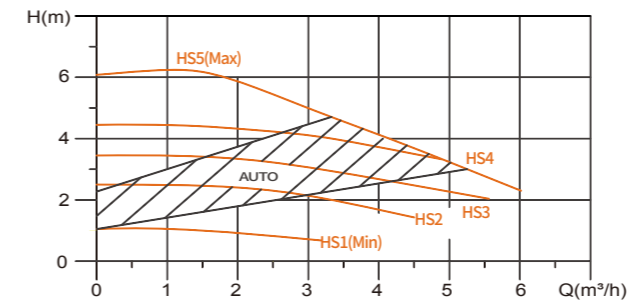

GPAXX-6 IV Performance curves (BL)

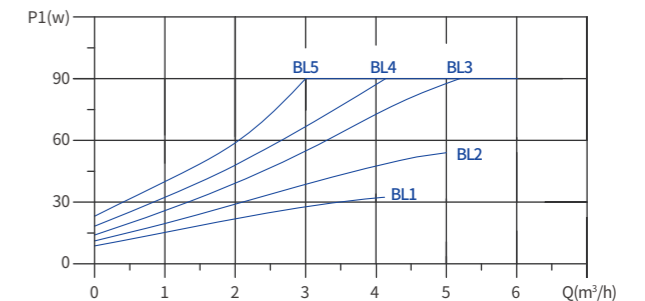
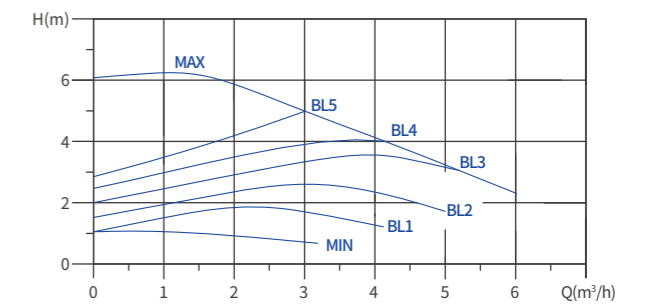

GPAXX-6 IV Performance curves (HD)

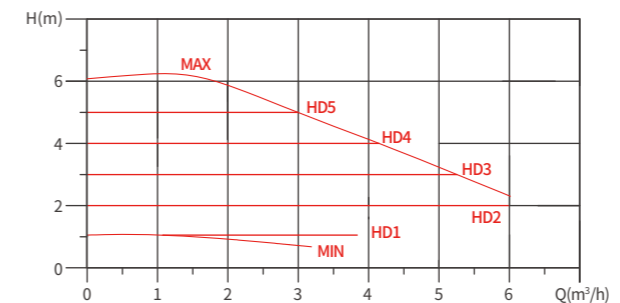

GPAXX-6 IV Performance curves (HD)

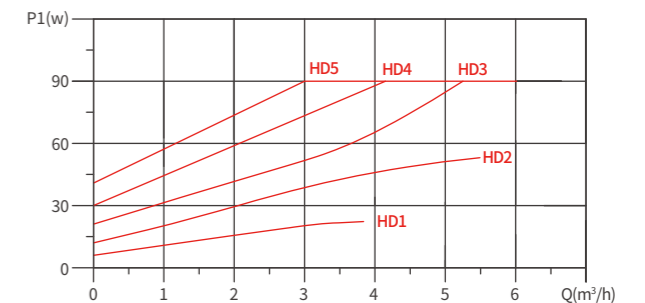

GPAXX-8 IV Performance curves (HS+AUTO)

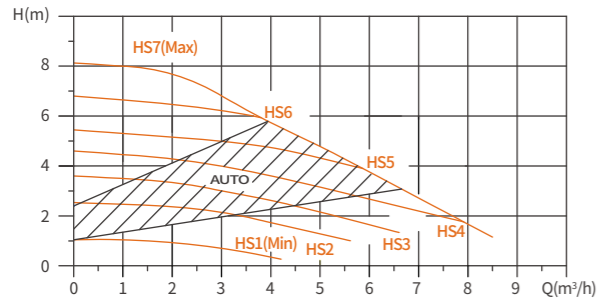

GPAXX-8 IV Performance curves (HS+AUTO)

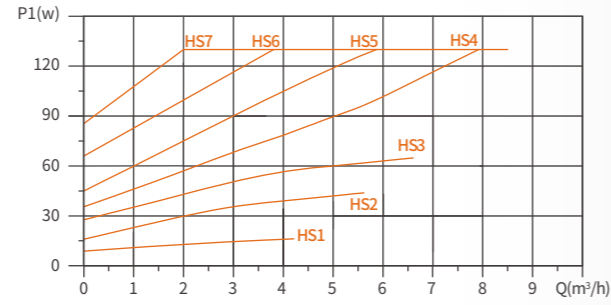

GPAXX-10 IV Performance curves (HS+AUTO)

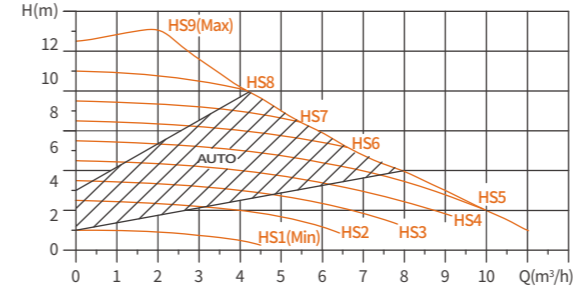

GPAXX-10 IV Performance curves (BL)

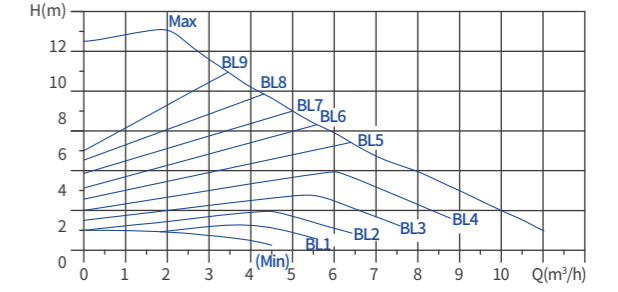

GPAXX-8 IV Performance curves (BL)

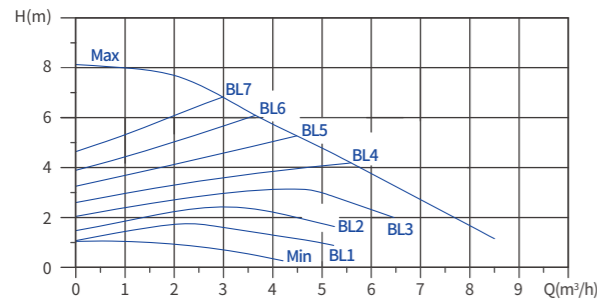

GPAXX-8 IV Performance curves (HD)

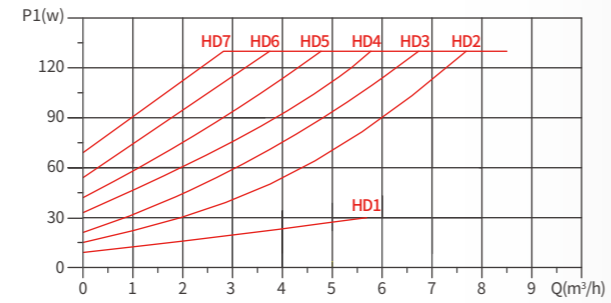
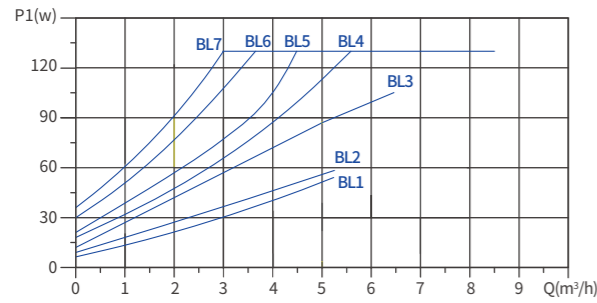
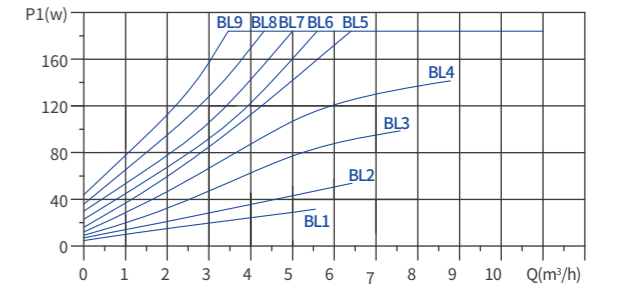
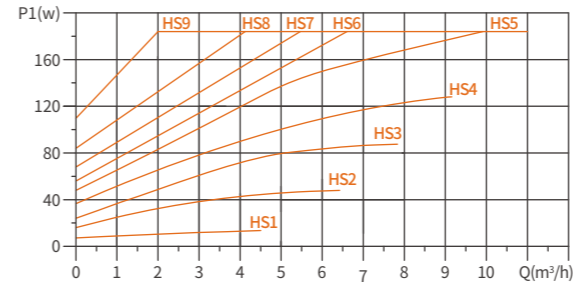
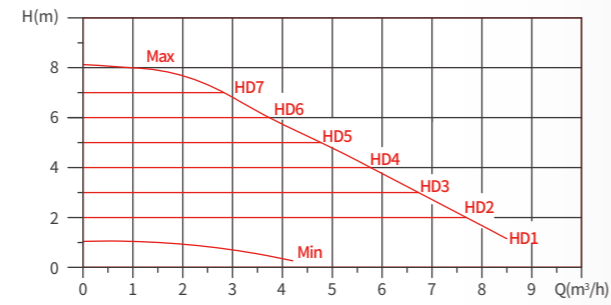

GPAXX-10 IV Performance curves (HD)

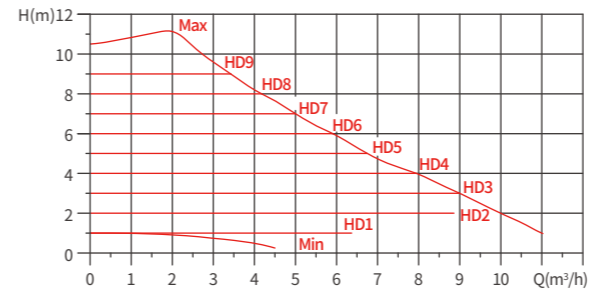

GPAXX-10 IV Performance curves (HD)

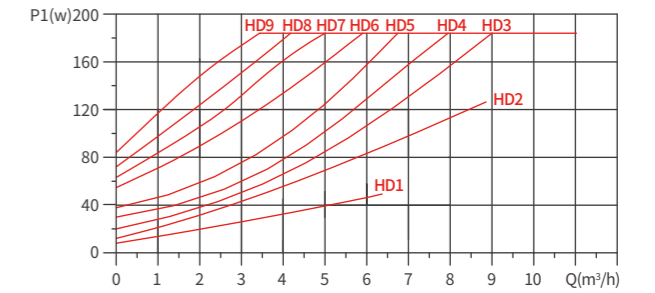

Installation drawing and performance parameter

Installation drawing—GPA IV (DN/DN32)

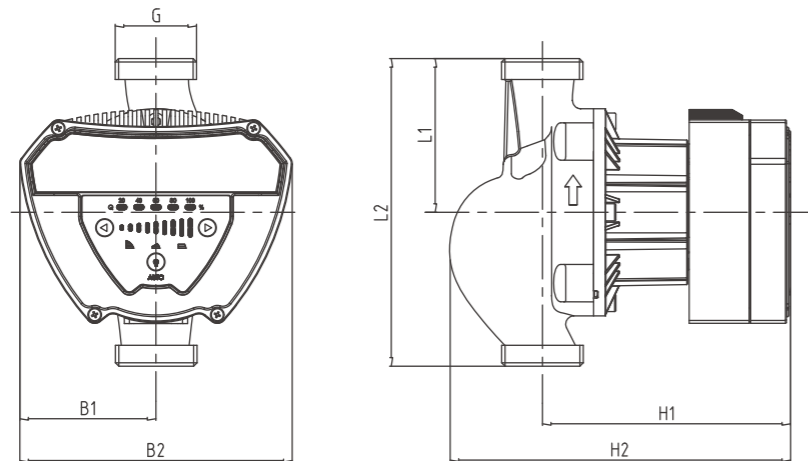

Model	Material of pump body		Dimension(mm)							Package size (mm*mm*mm)	Wt.(kg)	
	Cast iron	Stainless Steel	L1	L2	B1	B1	H1	H1	G	Inner box	G.W.	N.W.
GPA25-6 IV	●	●	90	180	80	160	140	199	11/2"	235x180x200	5.0	4.5
GPA32-6 IV	●		90	180	80	160	140	199	2"	235x180x200	5.5	5.0
GPA25-8 IV	●	●	90	180	80	160	140	199	11/2"	235x180x200	5.0	4.5
GPA32-8 IV	●		90	180	80	160	140	199	2"	235x180x200	5.5	5.0
GPA25-10 IV	●	●	90	180	80	160	140	199	11/2"	235x180x200	5.0	4.5
GPA32-10 IV	●		90	180	80	160	140	199	2"	235x180x200	5.5	5.0

Installation drawing—GPA F IV (DN40)

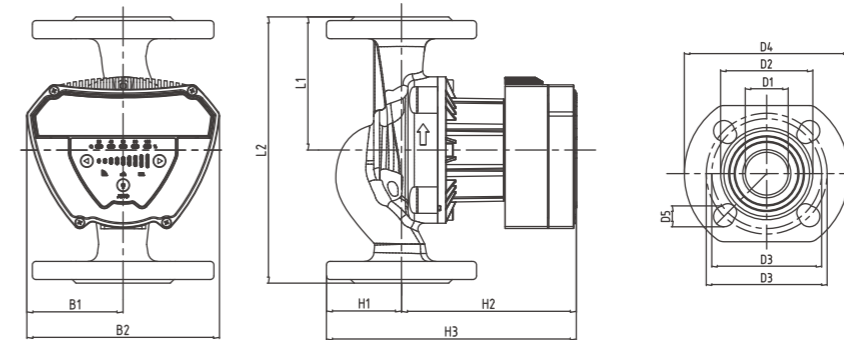

Model	Pump body material	Dimensions													Package size (mm*mm*mm)		Wt.(kg)	
	Cast iron	L1	L2	B1	B2	H1	H2	H3	D1	D2	D3	D4	D5	Inner box	G.W.	N.W.		
GPA40-6F IV	●	110	220	80	160	62	144	206	40	84	100/110	150	19	245x210x245	10.0	7.6		
GPA40-8F IV	●	110	220	80	160	62	144	206	40	84	100/110	150	19	245x210x245	10.0	7.6		
GPA40-10F IV	●	110	220	80	160	62	144	206	40	84	100/110	150	19	245x210x245	10.0	7.6		

Performance parameter

Model	Max. Flow (m³/h)	Max. Head (m)	Power(W)		Current(A)		Voltage/Frequency (V/Hz)
			Min.	Max.	Min.	Max.	
GPA25-6 IV	5.5	6	6	90	0.06	0.63	230V AC 50/60Hz
GPA25-8 IV	6.5	8	8	130	0.08	0.9	
GPA25-10 IV	7	10	10	185	0.1	1.25	
GPA25-6N IV	5.5	6	6	90	0.06	0.63	230V AC 50/60Hz
GPA25-8N IV	6.5	8	8	130	0.08	0.9	
GPA25-10N IV	7	10	10	185	0.1	1.25	
GPA32-6 IV	6.5	6	6	90	0.06	0.63	230V AC 50/60Hz
GPA32-8 IV	8	8	8	130	0.08	0.9	
GPA32-10 IV	10	10	10	185	0.1	1.25	
GPA40-6F IV	7.5	6	6	90	0.06	0.63	230V AC 50/60Hz
GPA40-8F IV	8.5	8	8	130	0.08	0.9	
GPA40-10F IV	10	10	10	185	0.1	1.25	

GPA xx-11

High Efficiency Circulation Pump



Applications

1. Domestic heating and hot water supply systems
2. Air and ground source heat pump systems
3. Air-conditioning systems
4. Industrial hot water circulation systems
5. Solar thermal system

Features and benefits

Easy installation and operation

Equipped with Self Adapting mode AUTO (default setting), pump runs once the power is connected and adapts its performance according to actual system needs.

Control is effected by digital pulse-width modulation (PWM) low-voltage signal, enabling pump to be used to meet different flow requirement in various systems.

Low noise and high comfort

Noise index: $\leq 42\text{dB(A)}$

Low energy consumption

A class energy efficiency, lowest power consumption up to 5W.

Multiple protection

With over-voltage and over-current protection.

Eco-Design Benchmark

$\text{EEI} \leq 0.23\text{-Part 2}$

Quick release power plug

Start-up and stop the pump quickly.

Product photo and control modes



Press button to switch between different control modes.
(HS1, HS2, HS3, AUTO, BL1, BL2, BL3, HD1, HD2, HD3)

Lighting area	Explanation	As shown in the figure
Factory settings	Highest to Lowest Proportional Pressure Curve	
HS1	Velocity I	
HS2	Velocity II	
HS3	Velocity III	
BL1	Lowest Proportional Pressure Curve	
BL2	Intermediate Proportional Pressure Curve	
BL3	Highest Proportional Pressure Curve	
HD1	Lowest Constant Pressure Curve	
HD2	Intermediate Constant Pressure Curve	
HD3	Highest Constant Pressure Curve	
PWM	Duty cycle and rotational velocity curve	

Technical parameter

Technical data

Power supply voltage	220-240V 50/60Hz, protective earth
Motor protection	No external protection required
IP class	IP44
Insulation class	H
Humidity (RH)	Max 95%
System pressure	1.0 MPa
Compliance	CE/ GS/ EMC/ LVD/RoHS/REACH
Environment temperature	0~+40°C
Temperature class	TF110
Liquid temperature	-30~+110°C(Glycol up to 50%)

Performance curves

Constant speed mode performance curve

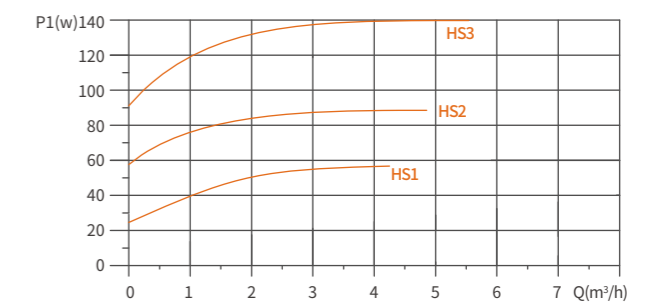
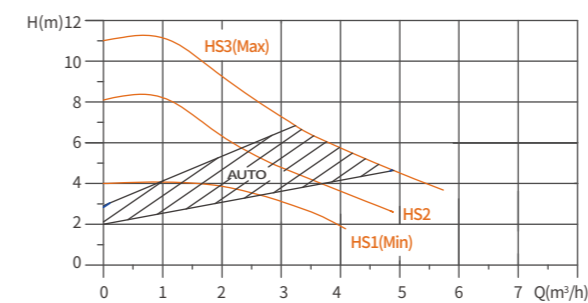

Installation drawing and performance parameter

Proportional pressure performance curve

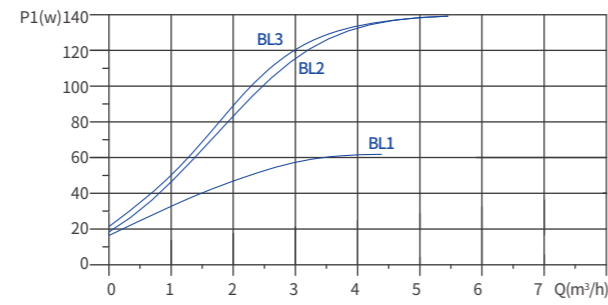
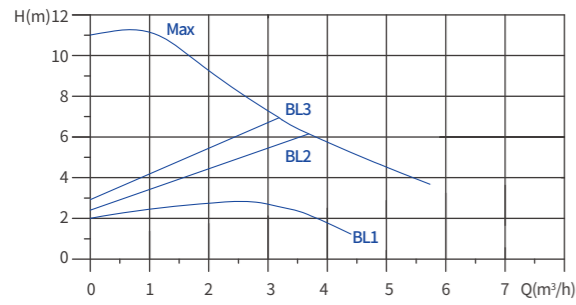

Constant pressure mode performance curve

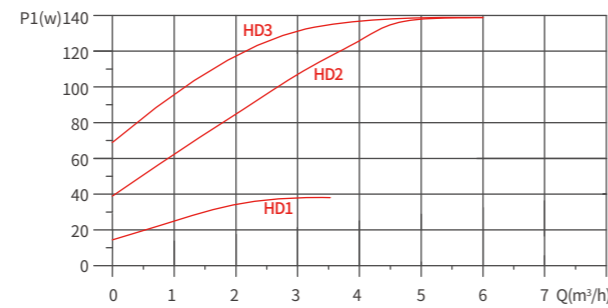
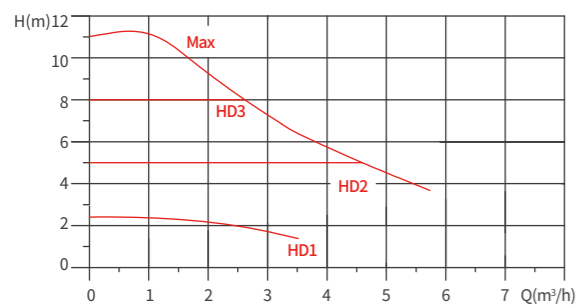

PWM mode performance curve

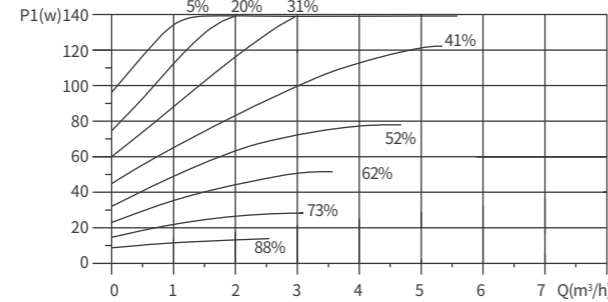
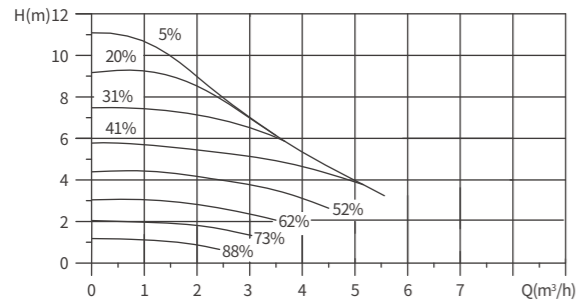

Installation drawing

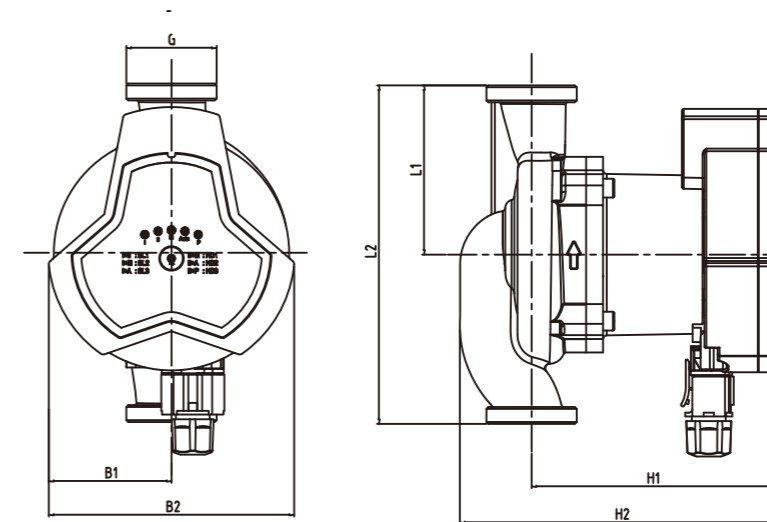

Performance parameter

Power (W)	Model	Max. Flow (m³/h)	Max. Head (m)	Amps (A)	V/Hz	Material	Dimension(mm)							Package size (mmxmmxmm)		Wt. (kg)	
							L1	L2	B1	B2	H1	H2	G	Inner box	G.W.	N.W.	
140	GPA25-11	5.5	11	1.0	●	●	90	180	66	132	132	170	1 1/2"	205x180x190	3.8	3.0	
	GPA32-11	7.0	11	1.0	●	●	90	180	66	132	132	170	2"	205x180x190	4.0	3.2	

GPA 15-1.5

High Efficiency Circulation Pump



Applications

1. Domestic heating and hot water circulation systems
2. Hot water heater circulation systems

Features and benefits

Easy installation and operation

Equipped with Self Adapting mode AUTO (default setting), pump runs once the power is connected and adapts its performance according to actual system needs.

Equipped with external temperature control, timing and pipeline flushing function.

Low noise and high comfort

Noise index: $\leq 42\text{dB(A)}$

Low energy consumption

Power consumption between 5W and 8W.

Multiple protection

With over-current protection

Quick release power plug

Start-up and stop the pump quickly.

Product photo and control modes

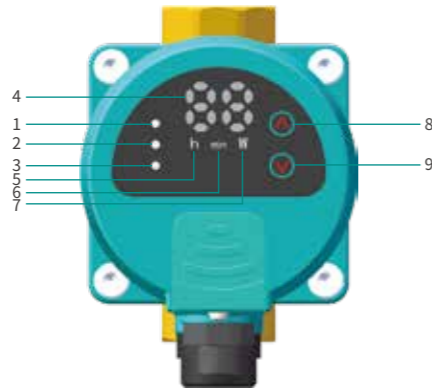

Position	Descriptions
1	Indicating constant speed running mode
2	Indicating Auto operation mode
3	Indicating temperature control mode
4	1. Power indicated 2. running (or stop) time indicated in timing mode
5	Running (or stop) hours set in timing mode for display
6	Running (or stop) minutes set in timing mode for display
7	Power unit shown under normal operation
8	1. Switch on various running modes 2. Increasing time in timing mode
9	Decreasing time in timing mode

◀ Press 8 and 9 button to switch between different control modes.

Technical parameter

Technical data

Power supply voltage	220-240V 50/60Hz, protective earth
Motor protection	No external protection required
IP class	IP44
Insulation class	F
Humidity (RH)	Max 95%
System pressure	1.0 MPa
Compliance	CE/ GS/ EMC/ LVD/RoHS/REACH
Environment temperature	0~+40°C
Temperature class	TF95
Liquid temperature	2~+110°C

Performance curves

Constant speed mode performance curve

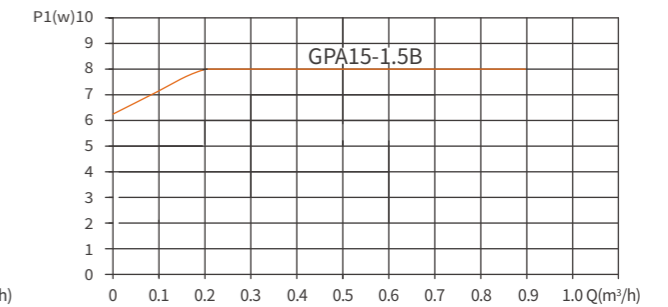
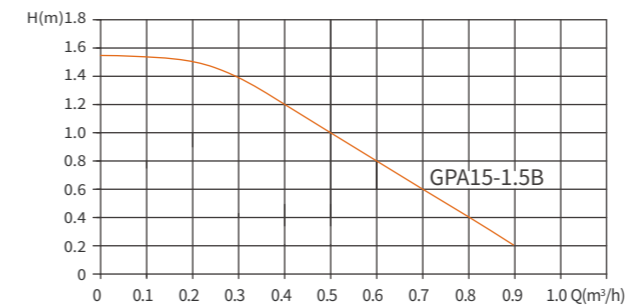

Installation drawing and performance parameter

Installation drawing

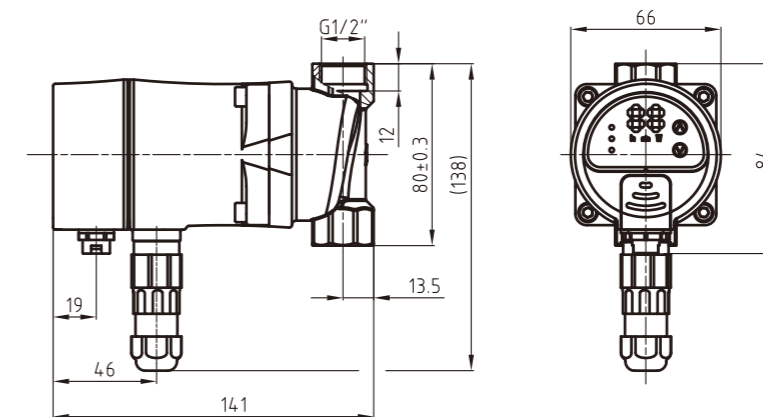

Performance parameter

Power (W)	Model	Max. Flow (m³/h)	Power Supply Voltage 220-240V, 50/60Hz	Material Copper	Control Mode of Motor Pump					Package size (mmxmmxmm)		Wt.(kg)	
					Constant speed running mode	Auto operation mode	Temperature Control mode	Timing mode	Flushing Function	Inner box	G.W.	N.W.	
8	GPA15-1.5B	0.9	●	●	●	●	●	●	●	180x115x150	1.2	1.0	
5	GPA15-1.5BL	0.7	●	●	●	●	/	/	/	180x115x150	1.2	1.0	

GPA 15-1.5 II BL

High Efficiency Circulation Pump



Applications

1. Domestic heating and hot water circulation systems
2. Hot water heater circulation systems

Features and benefits

Easy installation and operation

Equipped with Self Adapting mode AUTO (default setting), pump runs once the power is connected and adapts its performance according to actual system needs.

Equipped with external temperature control, timing and pipeline flushing function.

Low noise and high comfort

Noise index: $\leq 42\text{dB(A)}$

Low energy consumption

Power consumption between 5W and 8W.

Multiple protection

With over-current protection

Quick release power plug

Start-up and stop the pump quickly.

Product photo and control modes



Position	Descriptions
1	Indicating constant speed running mode

Technical parameter

Technical data

Power supply voltage	220-240V 50/60Hz, protective earth
Motor protection	No external protection required
IP class	IP44
Insulation class	F
Humidity (RH)	Max 95%
System pressure	1.0 MPa
Compliance	CE/ GS/ EMC/ LVD/RoHS/REACH
Environment temperature	0~+40°C
Temperature class	TF110
Liquid temperature	2~+110°C

Performance curves

Constant speed mode performance curve

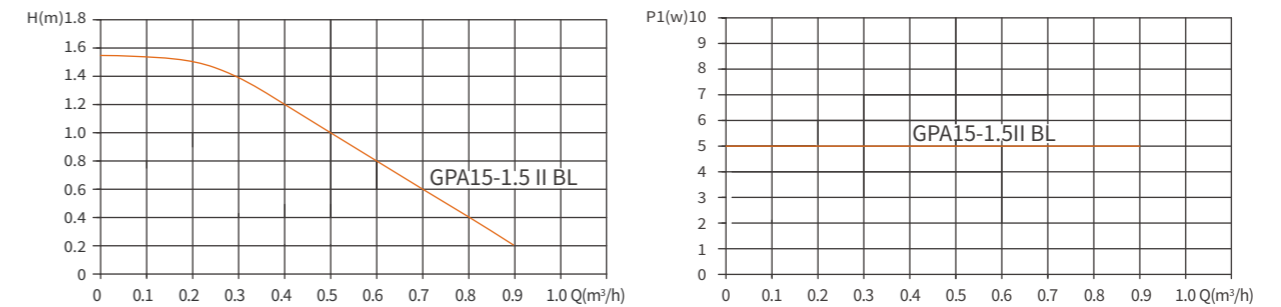

Installation drawing and performance parameter

Installation drawing

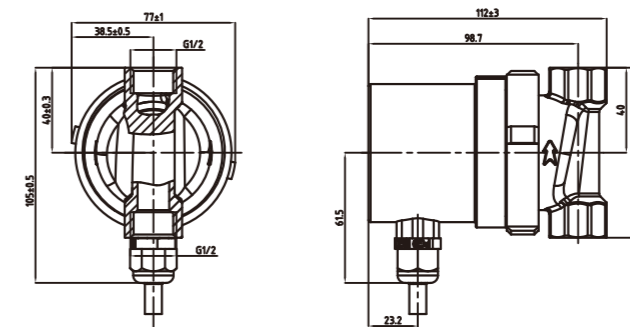

Performance parameter

Power (W)	Model	Max. Flow (m³/h)	Power Supply Voltage	Material	Control Mode of Motor Pump					Package size (mmxmmxmm)		Wt.(kg)	
					220-240V, 50/60Hz	Copper	Constant speed running mode	Auto operation mode	Temperature Control mode	Timing mode	Flushing Function	Inner box	G.W.
5	GPA15-1.5IIBL	0.9	●	●	●	/	/	/	/	180x115x150	1.2	1.0	

GPA 15-6F

High Efficiency Circulation Pump



Applications

1. Domestic heating and hot water supply systems
2. Air and ground source heat pump systems
3. Air-conditioning systems
4. Industrial hot water circulation systems
5. Solar thermal system

Features and benefits

Easy installation and operation

Equipped with Self Adapting mode AUTO (default setting), pump runs once the power is connected and adapts its performance according to actual system needs.

Equipped with temperature control

Low noise and high comfort

Noise index: $\leq 42\text{dB(A)}$

Low energy consumption

A class energy efficiency, lowest power consumption up to 5W.

Multiple protection

With over-voltage and over-current protection.

Product photo and control modes



- ◀ Press 3, 4 and 5 to switch between different control modes.
- ◀ The 2 area on terminal box is LCD display and shows the current

Technical parameter

Technical data

Power supply voltage	1×115V +10%/-15%, 50/60Hz, protective earth
Motor protection	No external protection required
IP class	IP42
Insulation class	H
Humidity (RH)	Max 95%
System pressure	1.0 MPa
Compliance	UL
Environment temperature	0~+40°C
Temperature class	TF110
Liquid temperature	-30~+110°C(Glycol up to 50%)

Performance curves

Constant speed mode performance curve

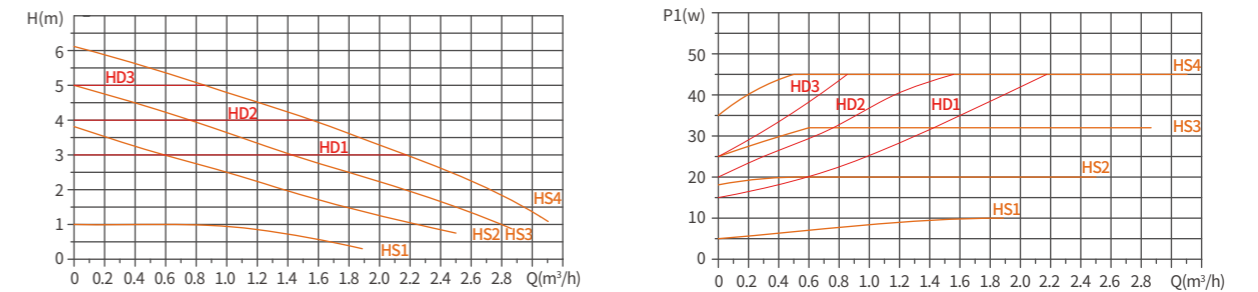

Installation drawing and performance parameter

Installation drawing

